

Pompa olejowa
Oil pump
Ölpumpe

HT 42.06-201.0

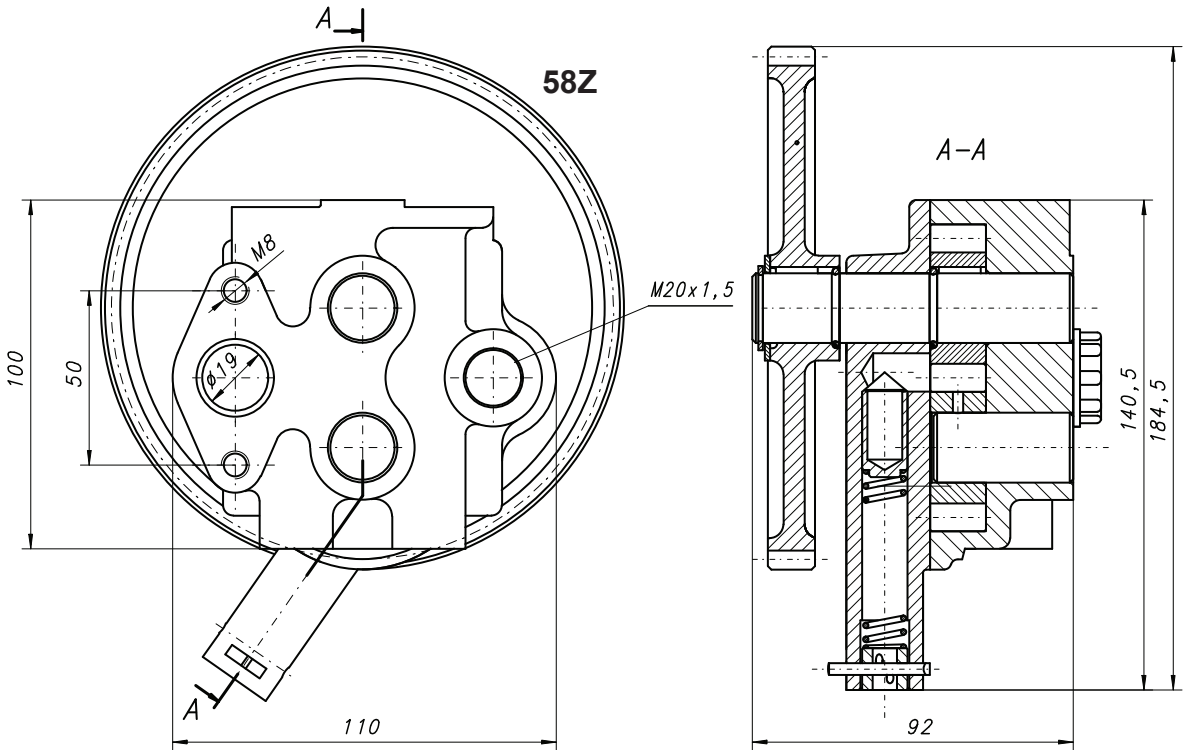

Informacje techniczne / Technical information / Technische Angaben			
Ciśnienie / Pressure / Druck	MPa	bar	psi
Nominalne / Nominal / Nominal	0,6	6	87
Maksymalne chwilowe / Intermittent/ Intermittierende	0,8	8	116
Obroty / Revolutions / Drehzahl	Min [min ⁻¹] 600	Max [min ⁻¹] 2000	
Objętość geometryczna / Volumetrical efficiency/ Fordervolumen	16,6 [cm ³ /U]		
Przepływ teoretyczny / theoretical flow / theoretisch Flussrate: n=1600 U/min, $\eta_{VT}=100\%$	$Q_T = 26,56$ l/min		
Waga / Weight / Gewicht	4 kg		