

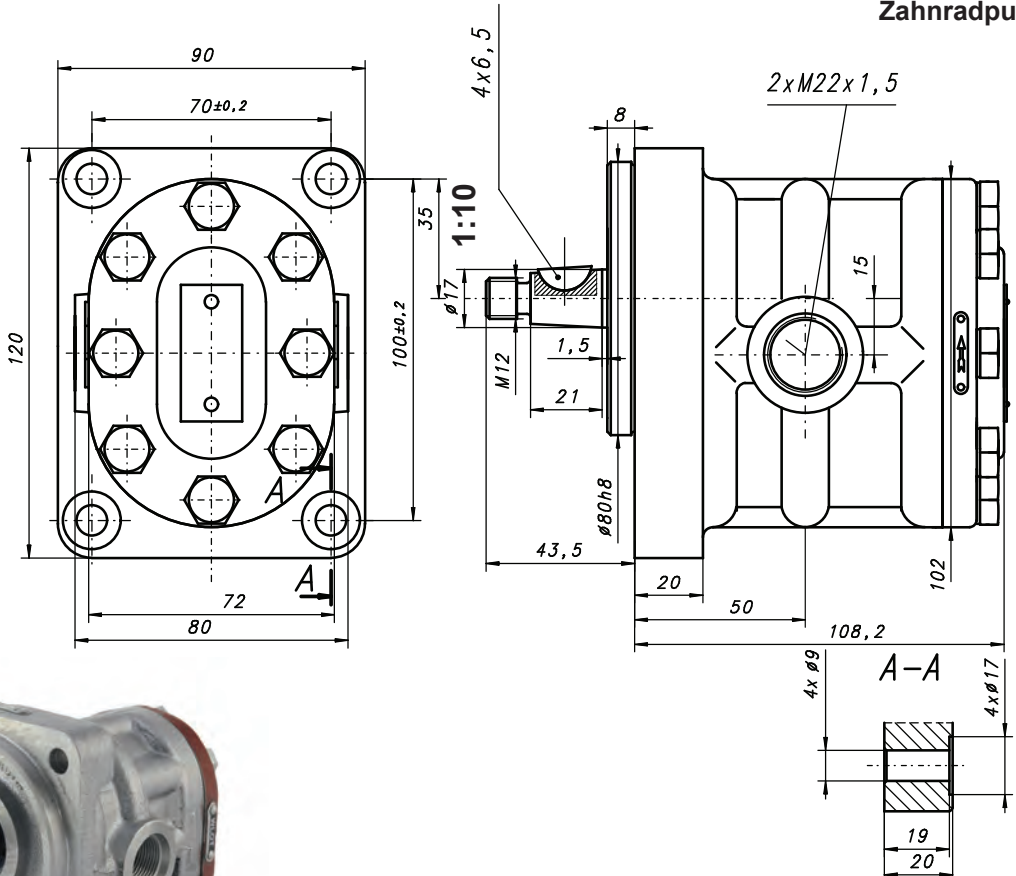

## PZ-18

 Pompa hydrauliczna  
 Hydraulic pump  
 Zahnradpumpe

Informacje techniczne / Technical information / Technische Angaben			
Ciśnienie / Pressure / Druck	MPa	bar	psi
Nominalne / Nominal / Nominal	10	100	1450
Maksymalne chwilowe / Intermittent/ Intermittierende	16	160	2320
Obroty / Revolutions / Drehzahl	Min [min <sup>-1</sup> ] 600	Max [min <sup>-1</sup> ] 2500	
Objętość geometryczna / Volumetrical efficiency/ Fordervolumen	15,2 [cm <sup>3</sup> /U]		
Kierunek obrotów /Revolutions / Drehrichtung	lewy / left / links		
Przepływ teoretyczny / theoretical flow / theoretisch Flussrate: n=1600 U/min, η <sub>VT</sub> =100%	Q <sub>T</sub> = 24,32 l/min		
Waga / Weight / Gewicht	4,8 kg		